



# ZEB HBY001

EN Instruction Manual  
FR Mode d'emploi  
DE Anwendung  
IT Manuale d'uso  
NL Gebruiksaanwijzing  
SE Bruksanvisning  
SI Navodila za uporabo  
FI Käyttöopas  
HR Korisnički priručnik  
ES Manual de instrucciones



# Multi-Wattage LED HIGHBAY

**zebra®**  
13 boulevard du  
fort de Vaux  
75017 Paris FRANCE

## Installation Instructions

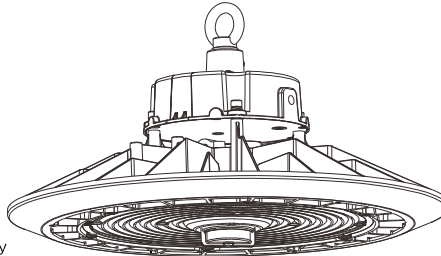

This product contains light source of energy efficiency class D.

 Non-replaceable light source

 Replaceable control gear by a professional

220-240VAC  
50/60Hz

 Do not stare at the operating light source

 Do not place on a flammable surface

 For indoor use

### Physical Dimensions (Unit: mm)

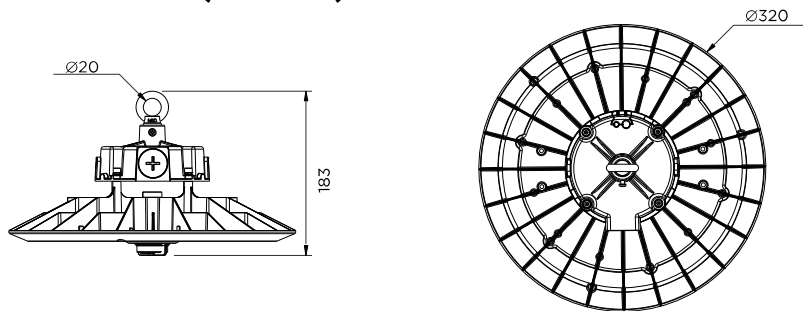

### Power Selectable

**Caution:**  
Please power off the luminaire before adjusting the DIP switch.  
Please do not use metal tool to adjust the DIP switch.  
Please adjust the switch gently.

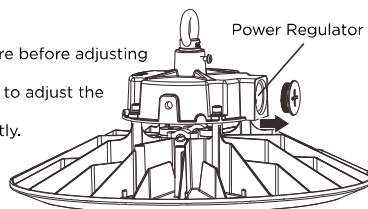

Power Selectable

A	B	C
200 (W)	150 (W)	100 (W)

### Sensor Mount

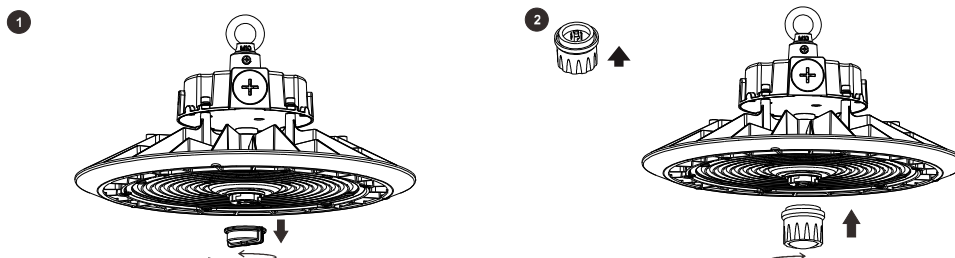

# Multi-Wattage LED HIGHBAY

**zebra®**  
13 boulevard du  
fort de Vaux  
75017 Paris FRANCE

## Suspension Mount

**1.** Make sure the screws are tightened

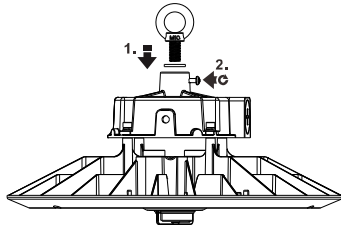

**2.** Recommended  
Hook Size:  
Ø6x60mm/  
Ø8x80mm

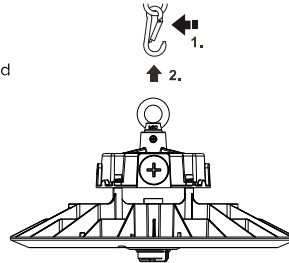

## Ceiling mount (Unit:mm)

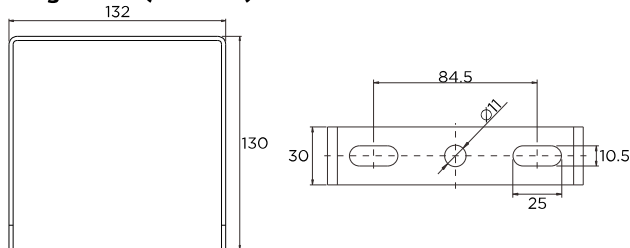

**1.**

M8  
2PCS  
8N.m

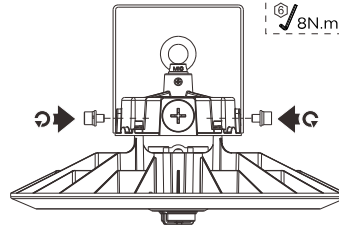

**2.**

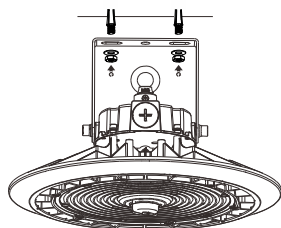

**3.**

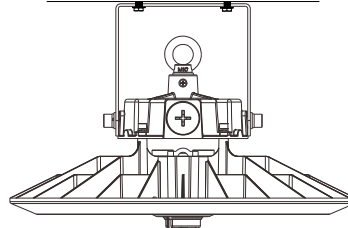

Power	100W, 150W, 200W
E-Number	2752010
Input Voltage	220-240V AC
Power Frequency	50 / 60 Hz
Product Dimension	Ø320x183mm
Luminaire Net Weight(±6%)	2.3kg
Working Temperature	-30°C to +50°C
Storing Temperature	-40°C to +70°C

\* Please subject to actual product for accurate weight.

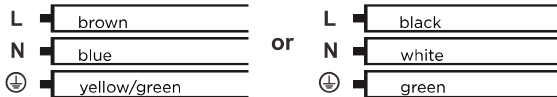

- The luminaire is suggested to be mounted above 4 meters height and indoor application.
- We highly suggest users to maintain and clean dust from the luminaire regularly, to keep its lifespan.
- The external flexible cable or cord of this luminaire cannot be replaced; if the cord is damaged, the luminaire shall be destroyed
- The light source of this luminaire is not replaceable; when the light source reaches its end of life the whole luminaire shall be replaced.



220-240V AC 50/60Hz IP65 IK08 Ta50°C

# LED multi-puissance HIGHBAY FR

**zebra®**  
13 boulevard du  
fort de Vaux  
75017 Paris FRANCE

## Instructions d'installation

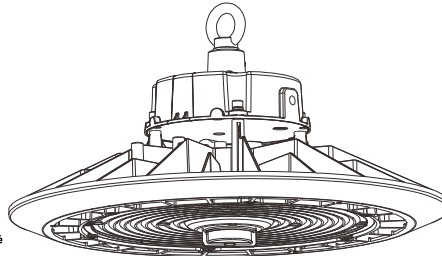

Ce produit contient une source lumineuse de classe d'efficacité énergétique D.

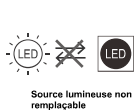

Source lumineuse non remplaçable



Boîtier de commande remplaçable par un professionnel.



220-240V CA  
50/60Hz



Ne pas fixer la source lumineuse en fonctionnement



Ne pas placer sur une surface inflammable



Pour une utilisation à l'intérieur

### Dimensions physiques (unité : mm)

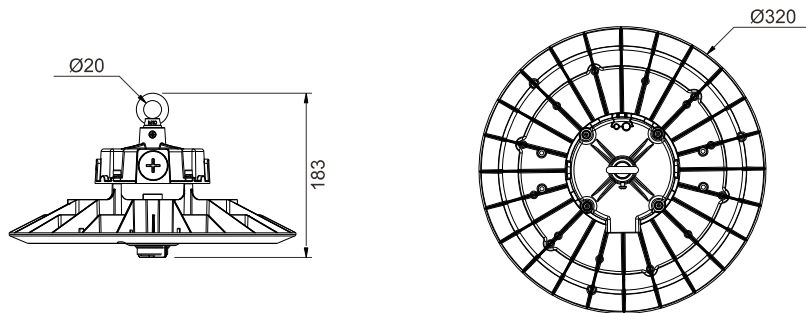

### Puissance sélectionnable

**Attention :**  
veuillez éteindre le luminaire avant de régler le commutateur DIP.  
N'utilisez pas d'outil métallique pour ajuster le commutateur DIP.  
Ajustez le commutateur avec précaution.

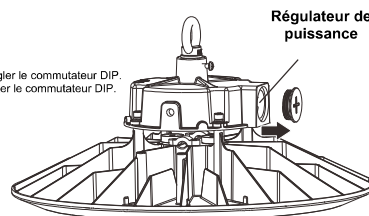

#### Puissance sélectionnable

A	B	C
200 (W)	150 (W)	100 (W)

### Montage du capteur

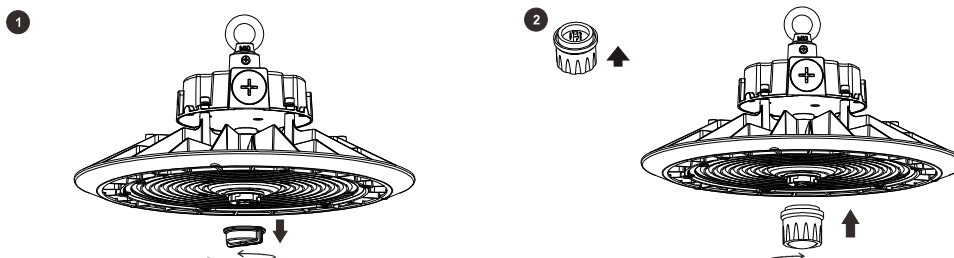

# LED multi-puissance HIGHBAY

FR

**zebra®**  
13 boulevard du  
fort de Vaux  
75017 Paris FRANCE

## Support de suspension

**1.** Assurez-vous que les vis sont bien serrées

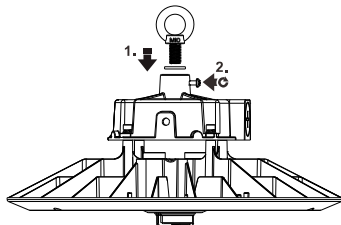

**2.** Taille de crochet recommandée :  
Ø6 x 60 mm/  
Ø8 x 80 mm

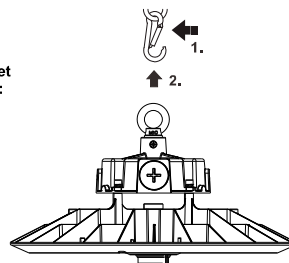

## Montage au plafond (unité : mm)

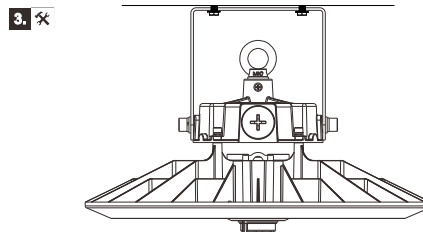
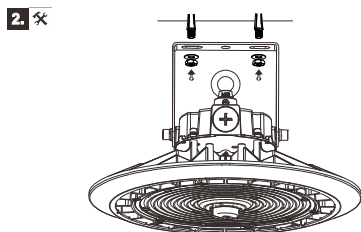
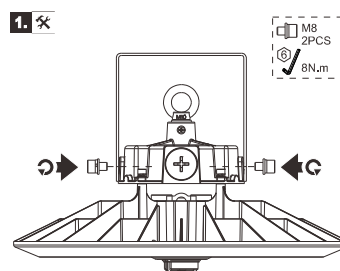
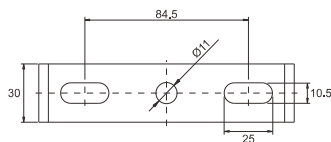
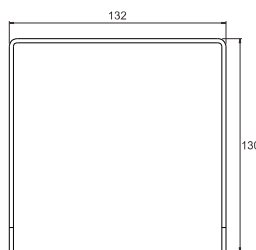

Power	100W, 150W, 200W
Numéro E	2752010
Tension d'entrée	220-240V CA
Puissance Fréquence	50 / 60 Hz
Dimension du produit	Ø320x183mm
Poids net du luminaire (±6 %)	2,3 kg
Température de fonctionnement	-30 °C à +50 °C
Température de stockage	-40 °C à +70 °C

\* Veuillez vous référer au produit réel pour connaître le poids exact.

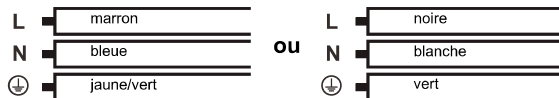

- Le luminaire est conseillé pour un montage à plus de 4 mètres de hauteur et pour une application en intérieur.
- Nous conseillons vivement aux utilisateurs d'entretenir et de dépoussiérer régulièrement le luminaire, afin de préserver sa durée de vie.
- Le câble flexible externe de ce luminaire ne peut pas être remplacé ; si le câble est endommagé, le luminaire sera détruit.
- La source lumineuse de ce luminaire n'est pas remplaçable ; lorsque la source lumineuse atteint sa fin de vie, le luminaire entier doit être remplacé.



220-240V CA 50/60Hz IP65 IK08 Ta 50°C

# Multi-Watt-LED HIGHBAY DE

**zebra®**  
13 boulevard du  
fort de Vaux  
75017 Paris FRANCE

## Einbauanleitung

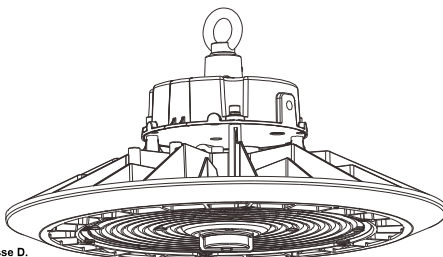

Dieses Produkt enthält eine Lichtquelle der Energieeffizienzklasse D.



Nicht austauschbare  
Lichtquelle



Ersetzbares Vorschaltgerät  
durch einen Profi.



Schauen Sie nicht direkt  
in die eingeschaltete  
Lichtquelle



Stellen Sie das Gerät  
nicht auf eine  
brennbare Oberfläche



Für den Gebrauch  
in Innenräumen

### Abmessungen (Einheiten: mm)

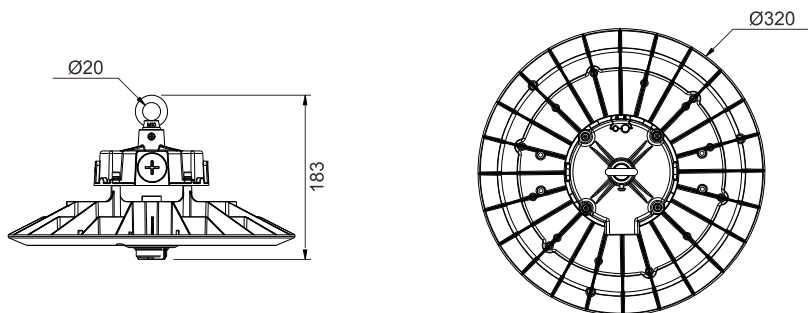

### Wählbare Leistung

**Vorsicht:**  
Bitte schalten Sie die Leuchte aus, bevor Sie  
den DIP-Schalter verstellen.  
Bitte verwenden Sie kein Metallwerkzeug,  
um den DIP-Schalter einzustellen.  
Bitte verstellen Sie den Schalter vorsichtig.

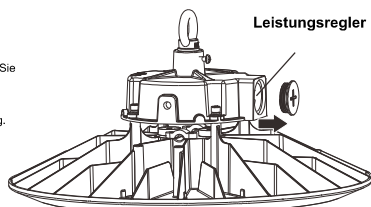

### Wählbare Leistung

A	B	C
200 (W)	150 (W)	100 (W)
■	■	■

### Sensor-Montage

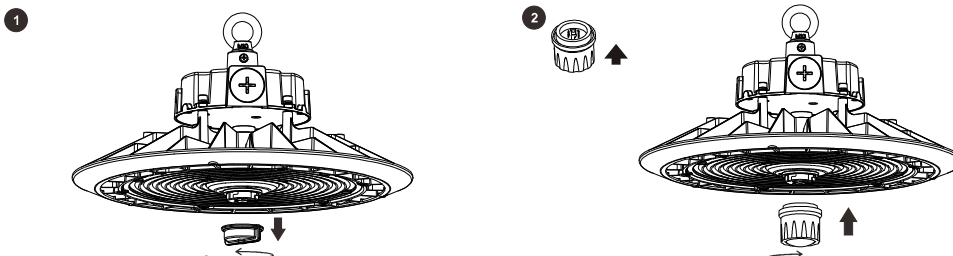

# Multi-Watt-LED HIGHBAY

DE

**zebra®**  
13 boulevard du  
fort de Vaux  
75017 Paris FRANCE

## Aufhängevorrichtung

**1.** ⚠ Stellen Sie sicher, dass die Schrauben fest angezogen sind

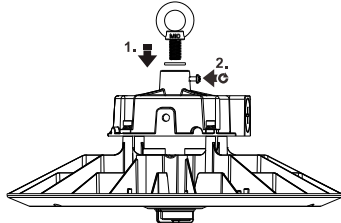

**2.** ⚠  
Empfohlene  
Hakengröße:  
Ø 6 x 60 mm/  
Ø 8 x 80 mm

**1.** ⬅  
**2.** ⬆

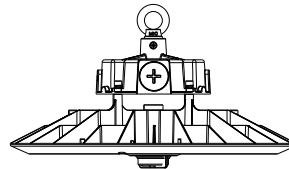

## Deckenhalterung (Einheit: mm)

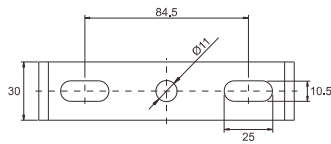
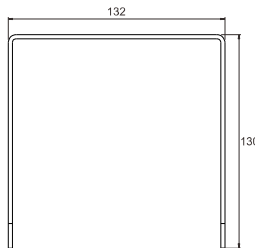

**1.** ⚠

M8  
2St.  
8N.m

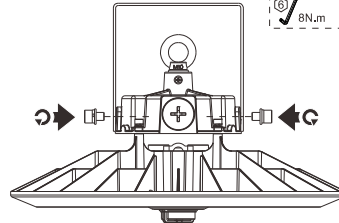

**2.** ⚠

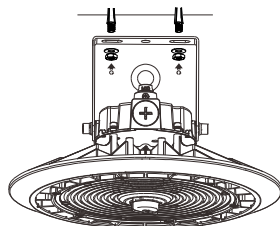

**3.** ⚠

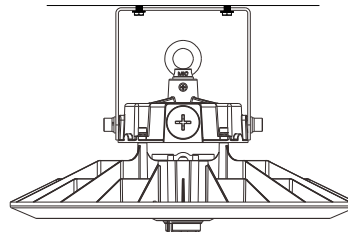

Leistung	100W, 150W, 200W
E-Nummer	2752010
Eingangsspannung	220-240V AC
Leistungsfrequenz	50 / 60 Hz
Produktmaße	Ø320x183mm
Luminaire Nettogewicht(+6 %)	2,3kg
Betriebstemperatur	-30°C to +50°C
Lagertemperatur	-40°C to +70°C

\* Das genaue Gewicht entnehmen Sie bitte dem tatsächlichen Produkt.

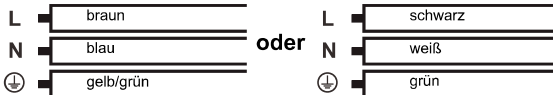

- Es wird empfohlen, die Leuchte in einer Höhe von mehr als 4 Metern zu montieren und in Innenräumen zu verwenden.
- Wir empfehlen Ihnen dringend, die Leuchte regelmäßig zu warten und von Staub zu befreien, um ihre Lebensdauer zu verlängern.
- Das externe flexible Kabel dieser Leuchte kann nicht ausgetauscht werden; wenn das Kabel beschädigt ist, muss die Leuchte entsorgt werden.
- Die Lichtquelle dieser Leuchte ist nicht austauschbar. Wenn die Lichtquelle das Ende ihrer Lebensdauer erreicht hat, muss die gesamte Lampe ersetzt werden.



220-240V AC 50/60Hz IP65 IK08 Ta50°C

# HIGHBAY LED multiwatt IT

**zebra®**  
13 boulevard du  
fort de Vaux  
75017 Paris FRANCE

## Istruzioni per l'installazione

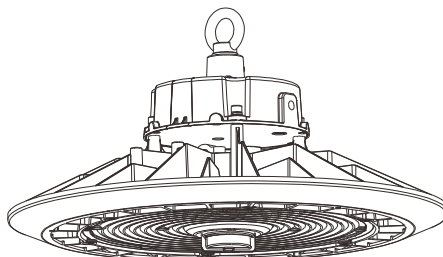

Questo prodotto contiene una sorgente luminosa con classe di efficienza energetica D.



Sorgente luminosa non sostituibile



Ingranaggio di comando sostituibile da un professionista.

220-240VAC  
50/60Hz



Non fissare con lo sguardo una fonte luminosa in funzione



Non posizionare su una superficie infiammabile



Per uso interno

### Dimensioni fisiche (unità: mm)

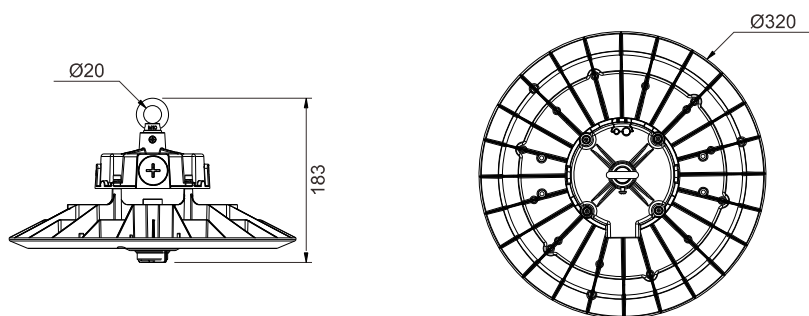

### Alimentazione selezionabile

**Attenzione:**  
Prima di regolare il DIP switch, scollegare l'apparecchio.  
Non usare strumenti metallici per regolare il DIP switch.  
Regolare l'interruttore con delicatezza.

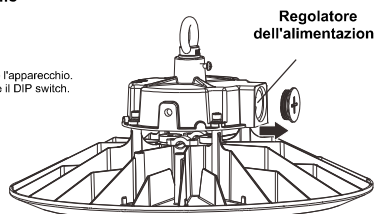

### Alimentazione selezionabile

A	B	C
200 (W)	150 (W)	100 (W)
■	□	□

### Supporto del sensore

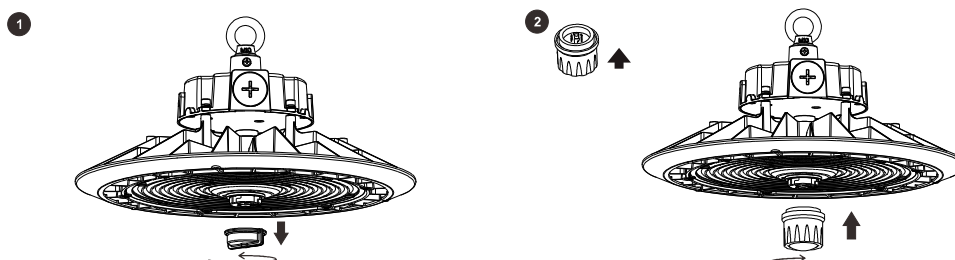

# HIGHBAY LED multiwatt



**zebra®**  
13 boulevard du  
fort de Vaux  
75017 Paris FRANCE

## Attacco per sospensione

**1.** Sincerarsi che le viti siano avvitate

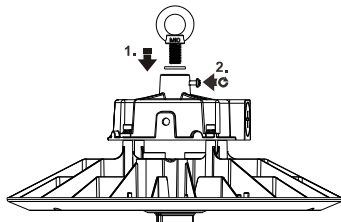

**2.** **Dimensioni raccomandate gancio:**  
Ø6x60mm/  
Ø8x80mm

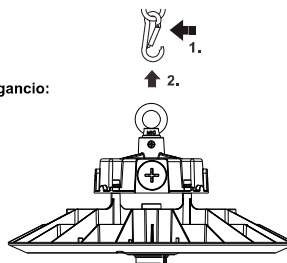

## Attacco a soffitto (unità: mm)

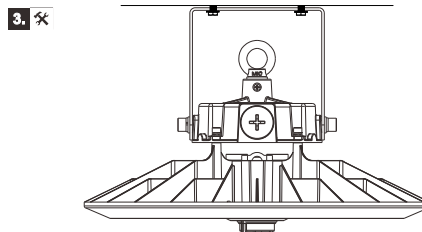
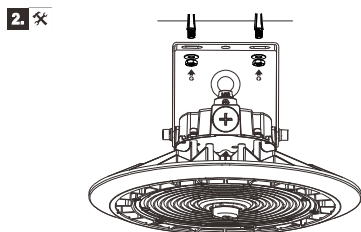
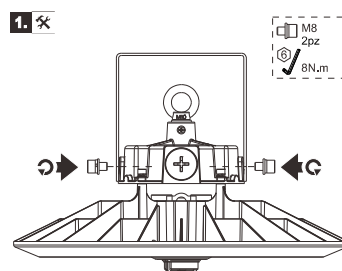
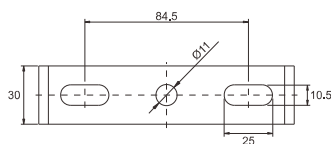
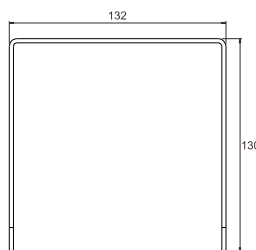

Alimentazione	100W, 150W, 200W
Codice E	2752010
Tensione d'ingresso	220-240V AC
Frequenza di alimentazione	50 / 60 Hz
Dimensioni del prodotto	Ø320x183mm
Peso netto apparecchio (±6%)	2,3kg
Temperatura di funzionamento	da -30°C a +50°C
Temperatura di conservazione	da -40°C a +70°C

\* Fare riferimento al prodotto specifico per il peso esatto.

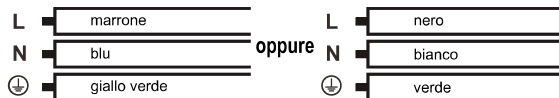

- L'apparecchio è adatto per il montaggio a un'altezza superiore a 4 metri e per un'applicazione al chiuso.
- Sugeriamo agli utenti di sottoporre l'apparecchio a manutenzione e a pulire la polvere regolarmente per aumentarne la durata del ciclo di vita.
- Il cavo o il filo flessibile esterno di questo apparecchio non può essere sostituito; se il filo è danneggiato, eliminare l'apparecchio
- La fonte luminosa di questo apparecchio non è sostituibile; quando arriva al termine della sua vita, l'intero apparecchio deve essere sostituito.



220-240V AC 50/60Hz IP65 IK08 Ta 50°C

# LED HIGHBAY met meerdere wattages

**zebra**  
13 boulevard du  
fort de Vaux  
75017 Paris FRANCE

## Installatie-instructies

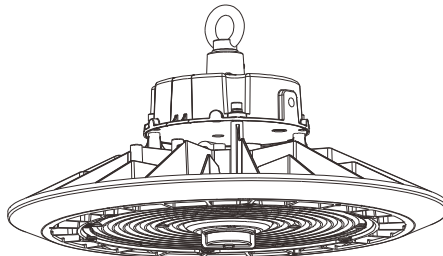

Dit product bevat lichtbronnen van energie-efficiëntieklasse D.



Niet-ervangbare  
lichtbron



Verwisselbaar voorschakelapparaat  
door een professional.

220-240VAC  
50/60Hz



Kijk niet naar de  
lichtbron



Niet op een brandbaar  
oppervlak plaatsen



Voor gebruik  
binnenshuis

### Fysieke afmetingen (eenheid: mm)

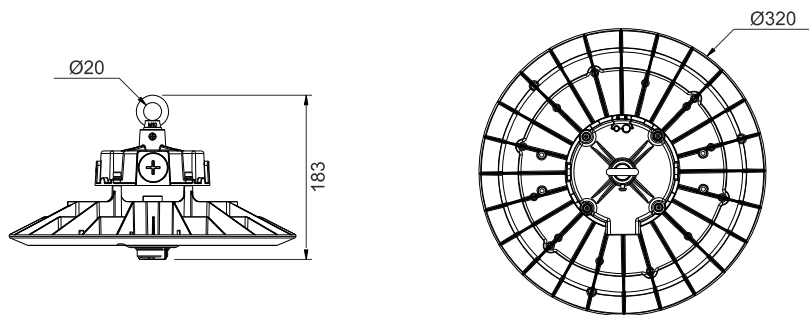

### Vermogen selecteerbaar

**Let op:**  
Schakel de armatuur uit voordat u de DIP-schakelaar aanpast.  
Gebruik geen metalen gereedschap om de DIP-schakelaar  
aan te passen.  
Pas de schakelaar voorzichtig aan.

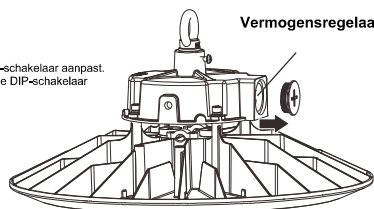

Vermogensregelaar

Vermogen  
selecteerbaar

A	B	C
200 (W)	150 (W)	100 (W)
<input type="checkbox"/>	<input type="checkbox"/>	<input type="checkbox"/>

### Sensor monteren

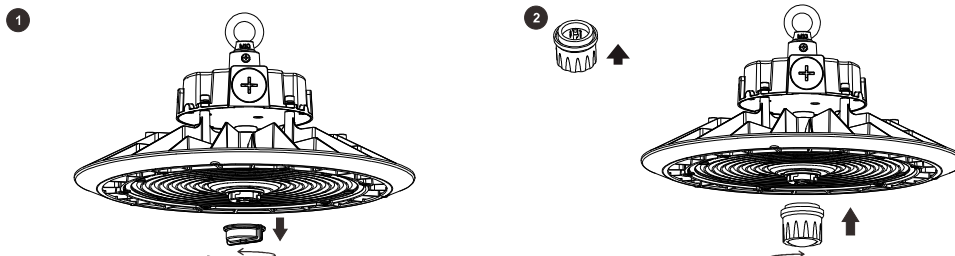

# LED HIGHBAY met meerdere wattages zebra®

13 boulevard du fort de Vaux  
75017 Paris FRANCE

## Ophangbevestiging

**1.**  Zorg ervoor dat de schroeven vastzitten

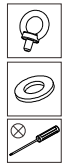
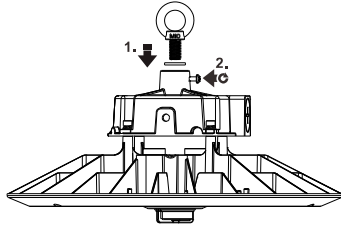

**2.**  Aanbevolen haakmaat: Ø6x60 mm/ Ø8x80 mm

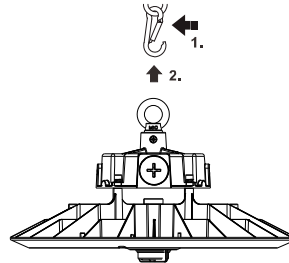

## Plafondbevestiging (eenheid: mm)

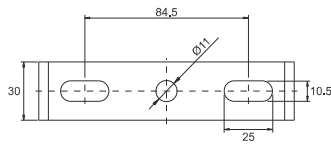
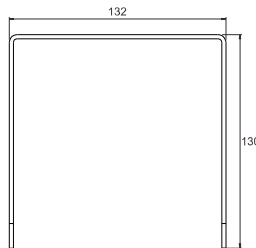

**1.** 

M8  
2st  
8N.m

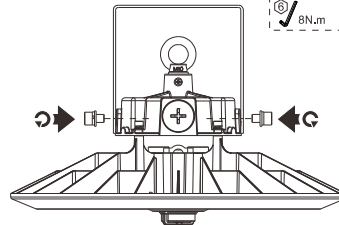

**2.** 

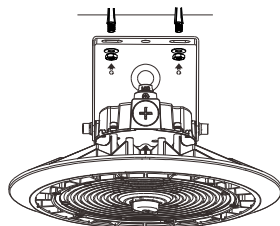

**3.** 

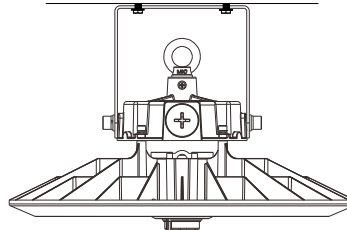

Vermogen	100W, 150W, 200W
E-nummer	2752010
Ingangsspanning	220-240V AC
Vermogensfrequentie	50 / 60 Hz
Afmetingen product	Ø320x183mm
Netto gewicht armatuur (± 6%)	2,3 kg
Bedrijfstemperatuur	-30 °C tot +50 °C
Opslagtemperatuur	-40 °C tot +70 °C

\* Kijk naar het daadwerkelijke product voor het juiste gewicht.

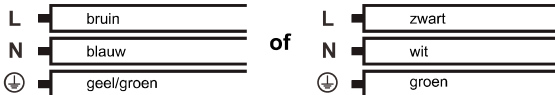

- De armatuur wordt aanbevolen voor montage boven de 4 meter hoogte en voor gebruik binnenshuis.
- We raden gebruikers ten zeerste aan om de armatuur regelmatig te onderhouden en stofvrij te maken, zodat deze langer meegaat.
- De externe flexibele kabel of het snoer van deze armatuur kan niet worden vervangen; als het snoer beschadigd is, moet de armatuur worden vernietigd.
- De lichtbron van deze armatuur is niet vervangbaar; wanneer de lichtbron het einde van zijn levensduur bereikt, moet de hele armatuur worden vervangen.



220-240V AC 50/60Hz IP65 IK08 Ta 50°C

# Multi-Watt LED HIGHBAY SE

**zebra®**  
13 boulevard du  
fort de Vaux  
75017 Paris FRANCE

## Installationsanvisningar

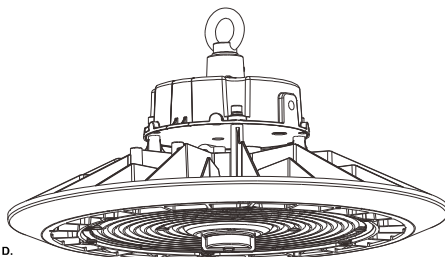

Denna produkt innehåller ljuskälla med energieffektivitetsklass D.



Ej utbyttbar ljuskälla



Utbytbara driftdon, byts av yrkeskunnig person.



220-240VAC  
50/60Hz



Stirra inte på den  
aktiva ljuskällan



Placera inte på en  
brandfarlig yta



För  
inomhusbruk

### Fysiska mått (Enhet: mm)

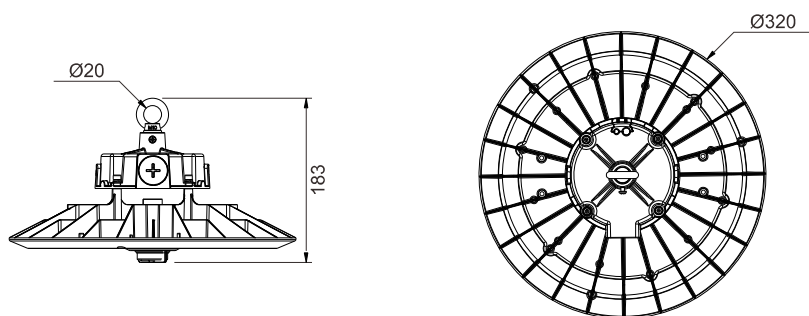

### Valbar effekt

**Försiktigt!**  
Släng av ljusarmaturen innan du justerar DIP-omkopplaren.  
Använd inte metallverktyg för att justera DIP-omkopplaren.  
Justera omkopplaren försiktigt.

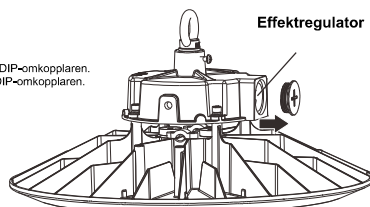

Effektregulator

#### Valbar effekt

A	B	C
200 (W)	150 (W)	100 (W)
■	■	■

### Sensorfäste

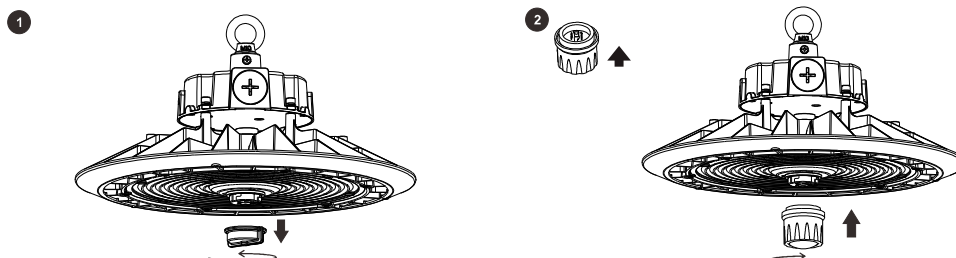

# Multi-Watt LED HIGHBAY



**zebra®**  
13 boulevard du  
fort de Vaux  
75017 Paris FRANCE

## Upphängningsfäste

**1.** Se till att skruvarna är åtdragna

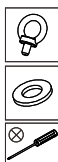
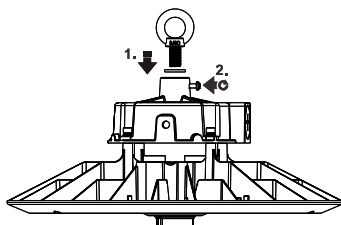

**2.**   
Rekommenderad  
krokstorlek:  
Ø 6 x 60 mm/  
Ø 8 x 80 mm

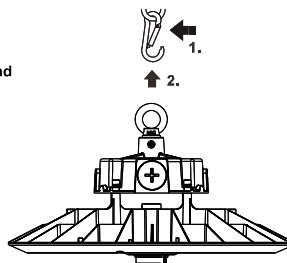

## Takmontering (Enhet: mm)

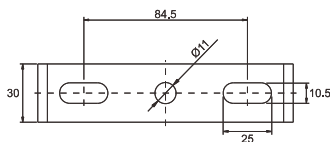
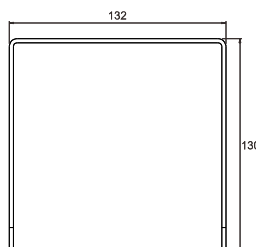

**1.**

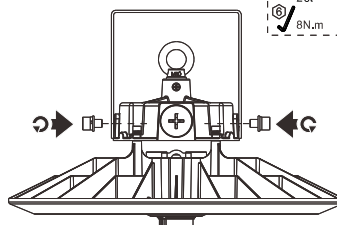

**2.**

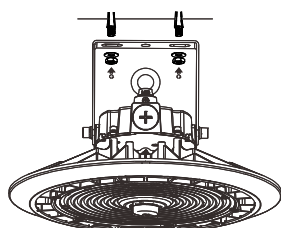

**3.**

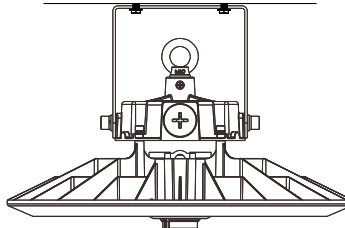

Effekt	100W, 150W, 200W
E-nummer	2752010
Inspänning	220-240V AC
Strömfrekvens	50 / 60 Hz
Produktens mått	Ø320x183mm
Ljusarmaturens nettovikt (±6 %)	2,3 kg
Arbetstemperatur	-30 °C till +50 °C
Förvaringstemperatur	-40 °C till +70 °C

\* Se faktisk produkt för korrekt vikt.

L	brun	eller	L	svart
N	blå		N	vit
	gul/grön			grön

- Det rekommenderas att ljusarmaturen monteras över 4 meters höjd och inomhus.
- Vi rekommenderar användare att underhålla och ta bort damm från ljusarmaturen regelbundet för att behålla dess livslängd.
- Den externa flexibla kabeln eller sladden till denna ljusarmatur kan inte bytas ut; om sladden är skadad ska armaturen förstöras
- Ljuskällan är inte utbytbar, vilket innebär att när den när slutet av sin tekniska livslängd ska hela ljusarmaturen bytas ut.



220-240V AC 50/60Hz IP65 IK08 Ta50°C

# LED HIGHBAY z regulacijo moči



**zebra®**  
13 boulevard du  
fort de Vaux  
75017 Paris FRANCE

## Navodilo za montažo

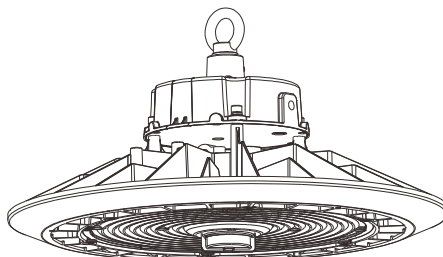

Ta izdelek vključuje svetlobni vir energijskega razreda D.



Ne zamenjajte svetlobni vir



Krmilni mehanizem mora zamenjati strokovnjak.

220-240VAC  
50/60Hz



Ne strmite v delujoč svetlobni vir



Ne postavljajte na vnetljivo površino



Za notranjo uporabo

### Fizične dimenzije (enota: mm)

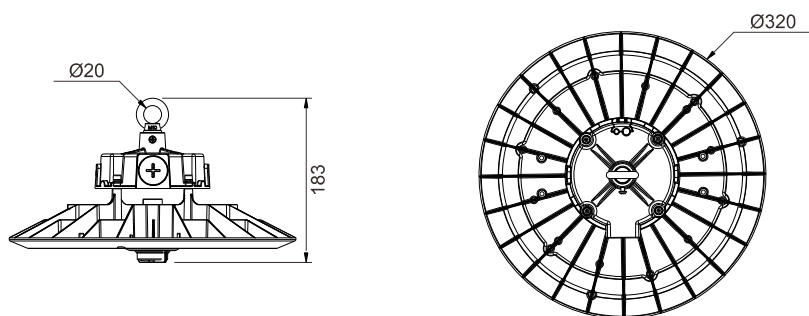

### Regulacija moči

**Opozorilo:**  
Pred nastavljanjem stikala DIP izklopite svetilo.  
Stikala DIP ne nastavljajte s kovinskim orodjem.  
Stikalo nastavite previdno.

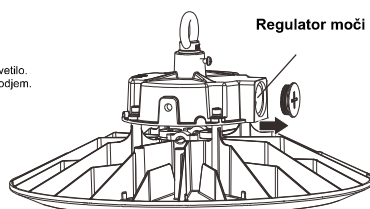

Regulator moči

### Regulacija moči

A	B	C
200 (W)	150 (W)	100 (W)

### Namestitev senzorja

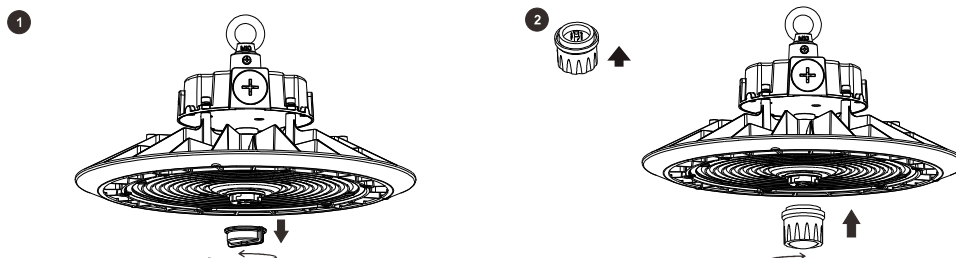

# LED HIGHBAY z regulacijo moči SI zebra®

13 boulevard du  
fort de Vaux  
75017 Paris FRANCE

## Obešalnik

**1.** Vijaki naj bodo čvrsto priviti

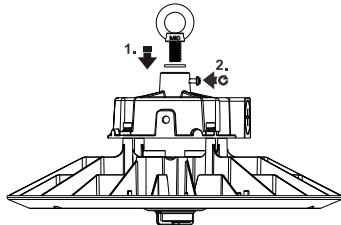

**2.**   
Priporočena  
velikost kljuke:  
Ø6x60 mm/  
Ø8x80 mm

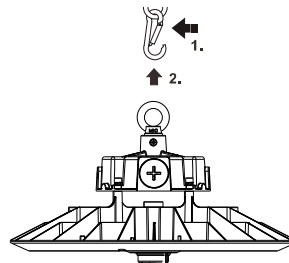

## Stropni nosilec (enota: mm)

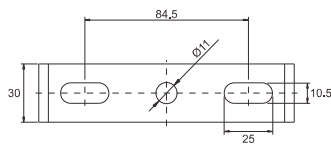
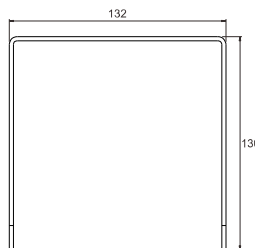

**1.**

M8  
2kosa  
8N.m

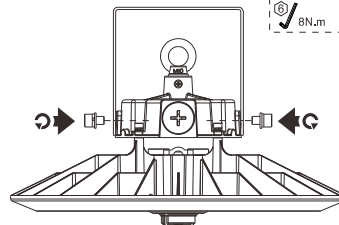

**2.**

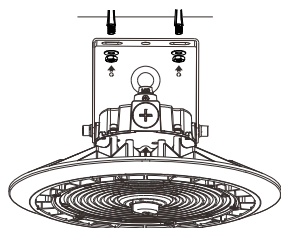

**3.**

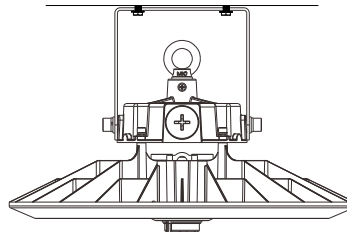

Moč	100W, 150W, 200W
E-številka	2752010
Vhodna napetost	220-240V AC
Frekvenca napetosti	50 / 60 Hz
Dimenzije izdelka	Ø320x183mm
Net teža svetila (±6 %)	2,3 kg
Delovna temperatura	-30°C do +50°C
Temperatura shranjevanja	-40°C do +70°C

\* Natančno težo preverite pri dejanskem izdelku.

L	rjavo	ali	L	črno
N	modro		N	belo
	rumena/zelena			zelena

- Priporočeno je, da svetilo namestite nad 4 m višine v notranjih prostorih.
- Uporabnikom močno priporočamo, da zaradi ohranitve življenjske dobe svetila z njega redno brišejo prah.
- Zunanjega gibkega kabla ali žice tega svetila ni mogoče zamenjati, zato je svetilo, če se žica poškoduje, uničeno.
- Svetlobnega vira tega svetila ni mogoče zamenjati, zato je treba svetlobni vir po koncu njegove življenjske dobe zamenjati.



220-240V AC 50/60Hz IP65 IK08 Ta 50°C

# Monitehoinen LED HIGHBAY

## Installation Instructions



zebra®  
13 boulevard du  
fort de Vaux  
75017 Paris FRANCE

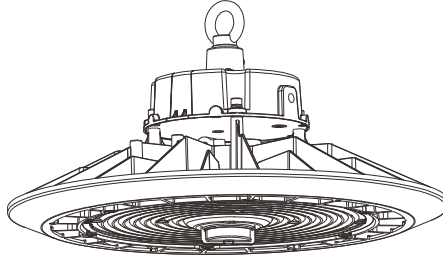

Tämä tuote sisältää energiatehokkuusluokan D valonlähteen.

 Ei-vaihdeettava valonlähde

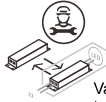

Vaihdeettava liitäntälaitte ammattilaisen toimesta

220-240VAC  
50/60Hz

 Älä tuijota käyttövaloa

 Älä aseta syttyvään pintakäyttöön



Sisälähteen

### Fyysiset mitat (yksikkö: mm)

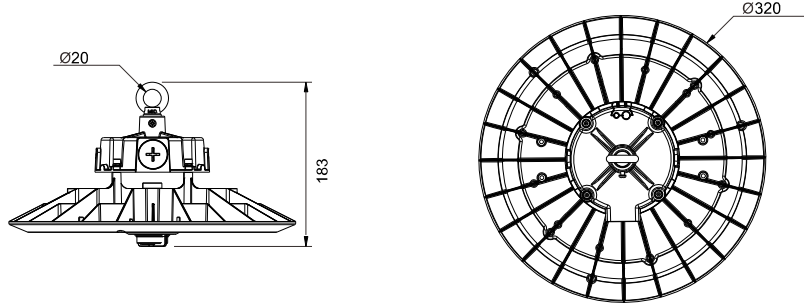

### Teho valittavissa

**Varoitus:**  
Kytke valaisimeen virta ennen DIP-kytkimen säätämistä.  
Älä käytä metallityökalua DIP-kytkimen säätämiseen.  
Säädä kytkintä varovasti.

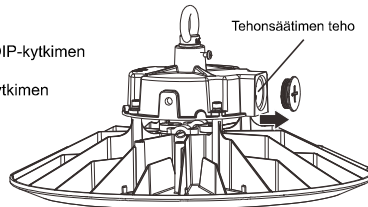

valittavissa

A	B	C
100 (W)	200 (W)	150 (W)

### Anturin kiinnitys

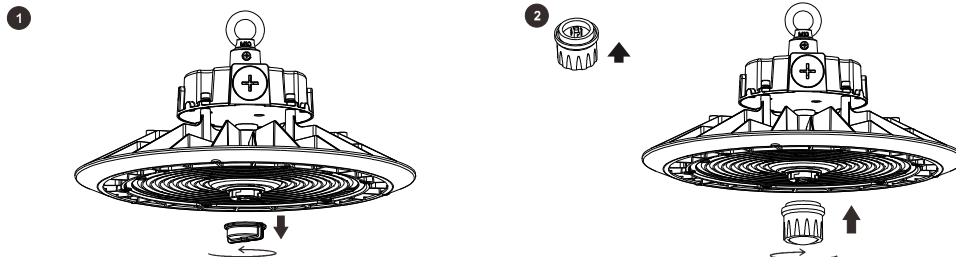

# Monitehoinen LED HIGHBAY



**zebra®**

13 boulevard du  
fort de Vaux  
75017 Paris FRANCE

## Jousituksen kiinnitys

**1.** Varmista, että ruuvit on kiristetty

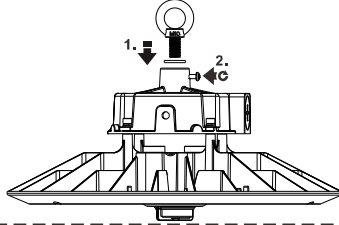

**2.**   
Suositeltu  
koukun koko:  
Ø6x60mm /  
Ø8x80mm

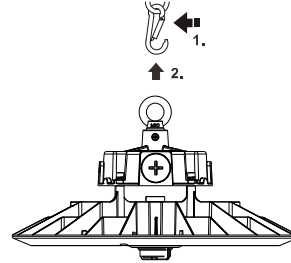

## Kattokiinnike (yksikkö:mm)

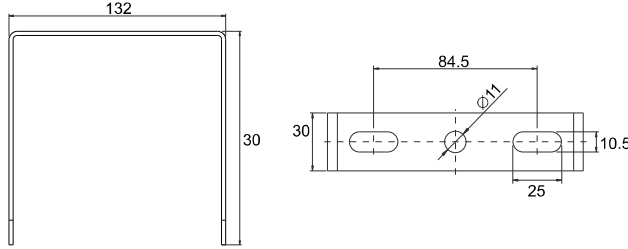

**1.**

M8  
2KPL  
8N.m

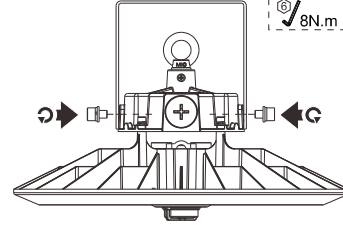

**2.**

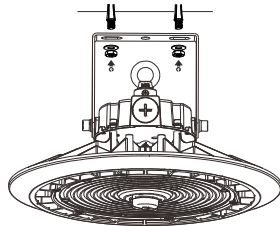

**3.**

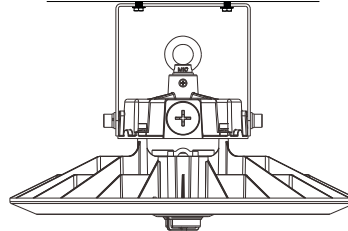

Valta	100W, 150W, 200W
E-numero	2752010
Tulojännite	220-240V AC
Tehon taajuus	50 / 60 Hz
Tuotteen dimensio	Ø320x183mm
Valaisimen nettopaino(±6%)	2,3 kg
Käyttölämpötila	-30 °C ... +50 °C
Lämpötilan säilyttäminen	-40 °C ... +70 °C

\* Ole hyvä ja ilmoita todellinen tuote tarkan painon vuoksi.

L	ruskea	or	L	musta
N	sininen		N	valkoinen
⊕	keltainen/vihreä		⊕	vihreä

- Valaisinta suositellaan asennettavaksi yli 4 metrin korkeuteen ja sisäkäyttöön.
- Suosittelemme, että käyttäjät huoltavat ja puhdistavat pölyt valaisimesta säännöllisesti, jotta sen käyttöikä säilyy.
- Tämän valaisimen ulkoista joustavaa kaapelia tai johtoa ei voi vaihtaa; jos johto on vaurioitunut, valaisin on tuhottava. Tämän valaisimen
- valonlähde ei ole vaihdettava; kun valonlähde saavuttaa käyttöikänsä lopun, koko valaisin on vaihdettava.



220-240V AC 50/60Hz IP65 IK08 Ta50°C

# Više snaga LED HIGHBAY



**zebra®**  
13 boulevard du  
fort de Vaux  
75017 Paris FRANCE

## Installation Instructions

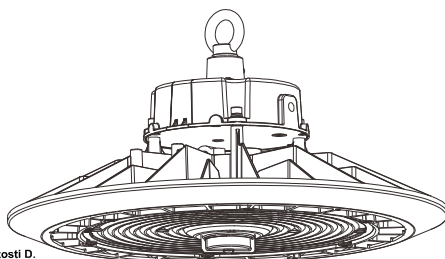

Ovaj proizvod sadrži izvor svjetlosti klase energetske učinkovitosti D.



Nezamjenjiv izvor svjetlosti



Profesionalno zamjenjiva upravljačka kutija.

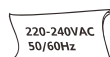

220-240VAC  
50/60Hz



Ne bujite u izvor  
svjetlosti u radu



Ne stavljajte na  
zapaljivu površinu



Za unutarnju  
uporabu

### Fizičke dimenzije (jedinica: mm)

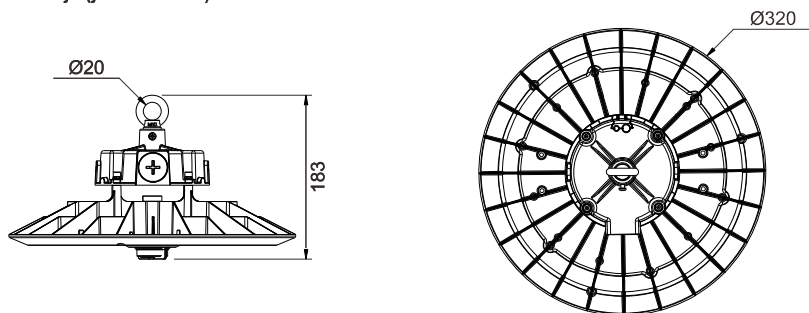

### Snaga koja se može odabrati

**Paznja:**  
Isključite učvršćenje prije podešavanja DIP prekidača.  
Ne koristite metalni alat za podešavanje DIP prekidača.  
Pažljivo podesite prekidač.

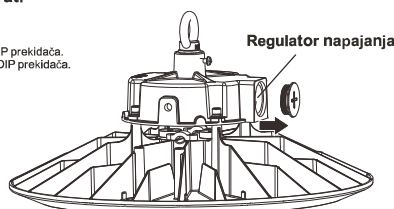

### Snaga koja se može odabrati

A	B	C
200 (W)	150 (W)	100 (W)

### Montiranje senzora

1

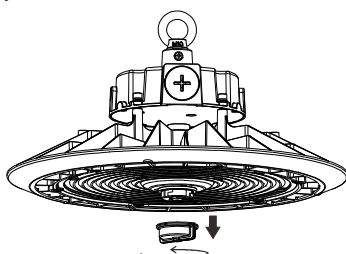

2

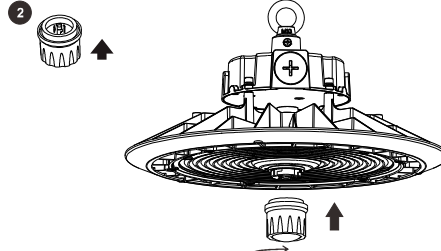

# Više snaga LED HIGHBAY



**zebra®**  
13 boulevard du  
fort de Vaux  
75017 Paris FRANCE

## Zagrada ovjesa

1. ✖ ⚠ Provjerite jesu li vijci zategnuti

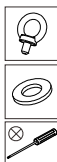
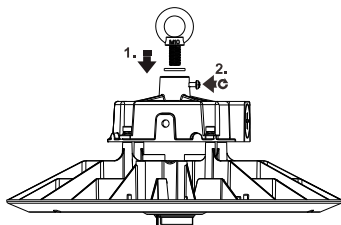

2. ✖  
Preporučena  
veličina kuke:  
Ø6x60mm/  
Ø8x80mm

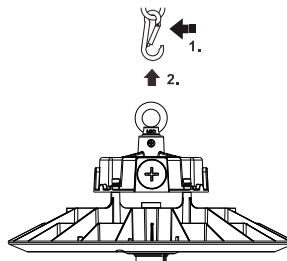

## Stropni nosač (jedinica: mm)

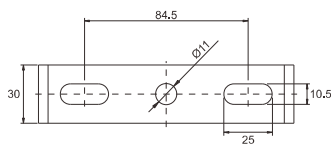
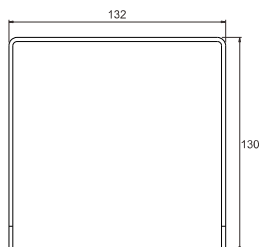

1. ✖

M8  
2PCS  
8Nm

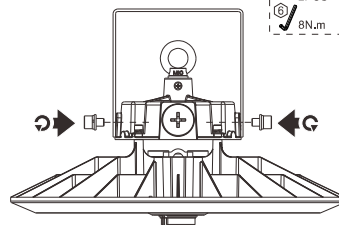

2. ✖

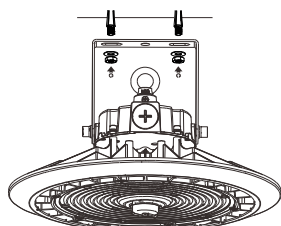

3. ✖

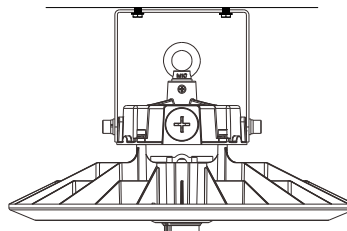

Moć	100W, 150W, 200W
Broj E	2752010
Ulazni napon	220-240V AC
Frekvencija	50 / 60 Hz
Dimenzija proizvoda težina	Ø320x183mm
svjetiljke (±6%) Radna	2.3kg
temperatura Temperatura	-30°C to +50°C
skladištenja	-40°C to +70°C

\*Molimo pogledajte stvarni proizvod za točnu težinu..

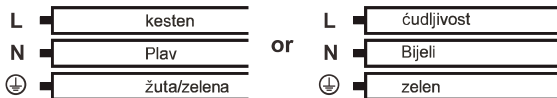

- Svjetiljka se preporučuje za ugradnju na visini većoj od 4 metra i za unutarnju primjenu.
- Savjetujemo korisnicima da redovito održavaju i brišu svjetiljku kako bi sačuvali njezin životni vijek.
- Vanjski fleksibilni kabel ovog učvršćenja ne može se zamijeniti; Ako je kabel oštećen, učvršćenje će biti uništeno.
- Izvor svjetlosti ove svjetiljke nije zamjenjiv; Kada izvor svjetlosti dosegne kraj svog života, cijela svjetiljka mora biti zamijenjena



220-240V AC 50/60Hz IP65 IK08 Ta 50°C

# LED multivatio HIGHBAY

## Installation Instructions

ES

**zebra®**  
13 boulevard du  
fort de Vaux  
75017 Paris FRANCE

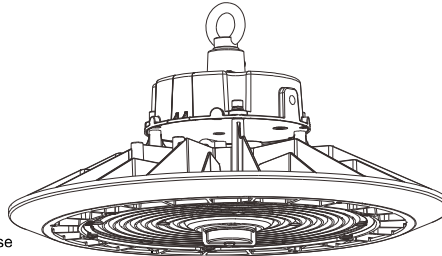

Este producto contiene una fuente de luz de clase de eficiencia energética D.

 Fuente de luz no reemplazable



Equipo de control reemplazable por un profesional

220-240VAC  
50/60 Hz

 No mire fijamente el de operación sobre fuentes

 No coloque en un inflamable superficies

 Para de interiores uso

### Dimensiones físicas (Unidad: mm)

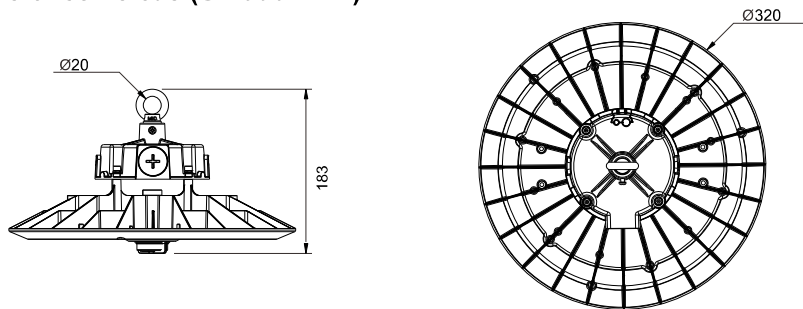

### Potencia seleccionable

**Cautela:**  
Encienda la luminaria antes de ajustar el interruptor DIP.  
No utilice una herramienta metálica para ajustar el interruptor DIP.  
Ajuste el interruptor suavemente.

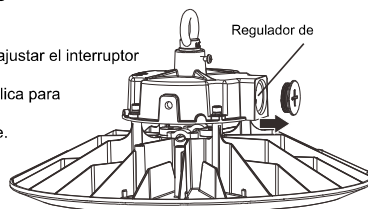

potencia seleccionable

A	B	C
100 (W)	200 (W)	150 (W)

### Montaje del sensor

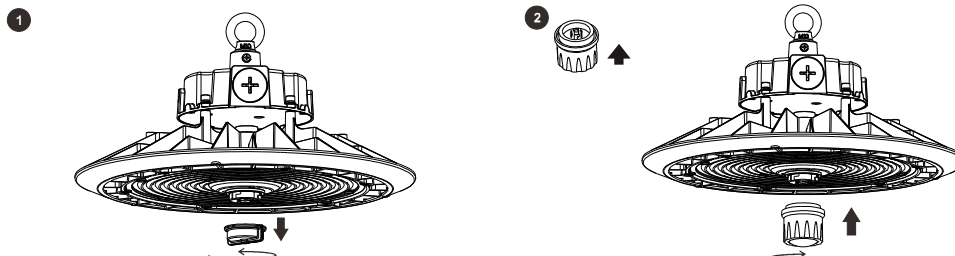

# LED multivatio HIGHBAY



**zebra®**  
13 boulevard du  
fort de Vaux  
75017 Paris FRANCE

## Montaje de suspensión

**1.** Asegúrese de que los tornillos estén apretados

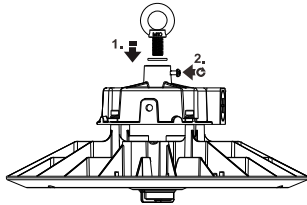

**2.** Recomendado  
Tamaño de gancho:  
Ø6x60mm /  
Ø8x80mm

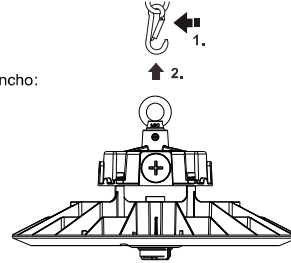

## Montaje en techo (Unidad: mm)

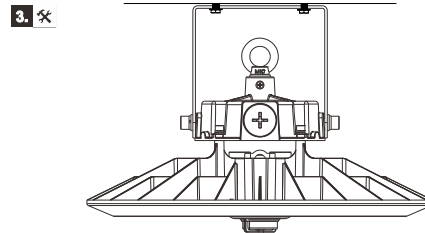
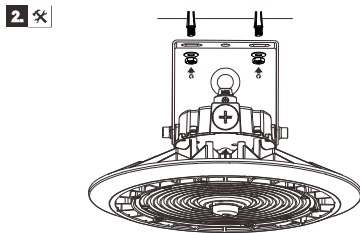
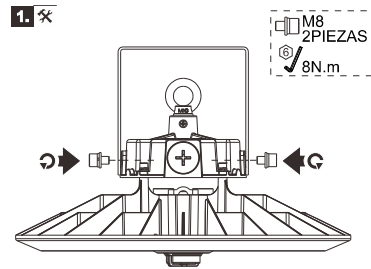
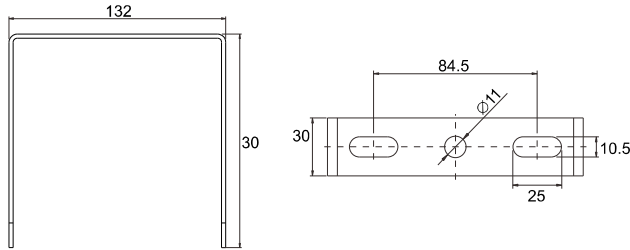

Poder	100 W, 150 W, 200 W
Número E	2752010
Voltaje de entrada	220-240 V CA
Frecuencia de potencia	50 / 60 Hz
Dimensión del producto	Ø320x183mm
Peso neto de la luminaria (±6%)	2,3 kg
Temperatura de trabajo	De -30 °C a +50 °C
Temperatura de almacenamiento	De -40 °C a +70 °C

\* Por favor, sujeto al producto real para el peso exacto.

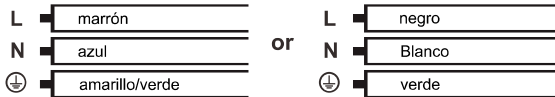

- Se sugiere montar la luminaria por encima de los 4 metros de altura y su aplicación en interiores.
- Recomendamos encarecidamente a los usuarios que mantengan y limpien el polvo de la luminaria con regularidad para mantener su vida útil.
- El cable o cordón flexible externo de esta luminaria no se puede reemplazar; si el cable está dañado, la luminaria se destruirá. La fuente de luz de esta luminaria no es reemplazable; cuando la fuente de luz llegue al final de su vida útil, se reemplazará toda la luminaria.



220-240V CA 50/60Hz IP65 IK08 Ta50°C